

INVESTIGATION OF TEMPERATURES ATTAINED BY PLASTIC FUEL GAS PIPE INSIDE SERVICE RISERS

TR-30

2020



Foreword

This report was developed and published with the technical help and financial support of the members of the PPI (Plastics Pipe Institute). The members have shown their interest in quality products by assisting independent standards-making and user organizations in the development of standards, and also by developing reports on an industry-wide basis to help engineers, code officials, specifying groups, and users.

The purpose of this technical report is to provide essential information on a particular aspect of thermoplastic piping to engineers, users, contractors, code officials and other interested parties.

This report has been prepared by PPI as a service of the industry. The information in this report is offered in good faith and believed to be accurate at the time of its preparation, but is offered “as is” without any express or implied warranty, including WARRANTIES OF MERCHANTABILITY AND FITNESS FOR A PARTICULAR PURPOSE. Any reference to or testing of a particular proprietary product should not be construed as an endorsement by PPI, which does not endorse the proprietary products or processes of any manufacturer. The information in this report is offered for consideration by industry members in fulfilling their own compliance responsibilities. PPI assumes no responsibility for compliance with applicable laws and regulations.

PPI intends to revise this report from time to time, in response to comments and suggestions from users of the report. Please send suggestions of improvements to the address below. Information on other publications can be obtained by contacting PPI directly or visiting the web site. This report was reviewed and revised and republished in Jan. 2020, adding APPENDIX A – 2017-2019 test data conditions and results and APPENDIX B – 1970’s test data which includes results and conclusions from that testing periods.

The Plastics Pipe Institute, Inc.

www.plasticpipe.org/

This Technical Report, TR-30, was first issued in May 1978 and was revised in September 1980, in October 1988, in December 2006, in December 2010 and March 2020.

© 2020 The Plastics Pipe Institute, Inc.

Table of Contents

1.0	Introduction.....	1
2.0	Conclusions.....	1
Appendix A 2017 - 2018 Test Data Investigation of Plastic Fuel Gas Pipe Inside Service Risers		3
1.0	Introduction.....	3
2.0	Test Assemblies	3
3.0	Field Site Configurations	8
4.0	Findings and Result.....	10
5.0	Influence of Temperature Cycling on Hydrostatic Design Properties of Polyethylene Pipe	13
Appendix B 1970's Test Data Investigation of Maximum Temperatures Attained by Plastic Fuel Gas Pipe Inside Service Risers		15
1.0	Introduction.....	15
2.0	Conclusions.....	15
3.0	Test Assemblies	16
4.0	Summary of Test Results And Observations.....	18
5.0	Estimated Service Riser Pipe Temperatures Across the U.S.	20
6.0	Influence of Temperature Cycling on Hydrostatic Design Properties of Polyethylene Pipe	22
7.0	Optimum Design for Thermoplastic Gas Pipe with Metal Sleeve Assembly	22
8.0	Thermoplastic Pipe Materials Having Design Stress Ratings for Higher Temperatures	23

Table of Figures

Figure A.1:	Cross sectional view of PE tubing in metal casing	4
Figure A.2:	Test Riser Assembly	5
Figure A.3:	Data logger housing	6
Figure A.4:	Installed data logger	6
Figure A.5:	Henderson, NV service risers (south facing).....	7
Figure A.6:	Henderson, NV riser assembly (west facing)	7
Figure A.7:	Henderson, NV site layout	8
Figure A.8:	Tempe, AZ site layout	9
Figure A.9:	Henderson average monthly riser temperatures @ different spacing ..	11
Figure A.10:	Henderson annual temperatures by month	11
Figure A.11:	Tempe average monthly riser temperatures @ different spacing.....	12
Figure A.12:	Tempe annual temperatures by month	13
Figure B.1:	Assembly Cross-section and Test Arrangement	17
Figure B.2:	Arrangement of Test Assemblies and Recorder with One Test Assembly Shaded and One Unshaded	18
Figure B.3:	Typical air vs. pipe temperatures	21

List of Tables

Table A.1:	Riser Placement and Description for Henderson, NV	8
Table A.2:	Riser Placement and Description for Tempe, AZ	9
Table A.3:	Temperature Variations Between Different Air-Gap spacings (Henderson, NV)	10
Table A.4:	Temperature Variations Between Different Air-Gap spacings (Tempe, AZ)	12
Table B.1:	Effect of Wall Contact.....	18
Table B.2:	Temperatures Attained by Plastic Pipe in Test Assemblies During Summer Seasons	19
Table B.3:	Temperatures Attained by Plastic Pipe in Test Assemblies During Winter Season	20
Table B.4:	Highest Temperature Data from Weather Stations Around the U.S.....	23

INVESTIGATION OF TEMPERATURES ATTAINED BY PLASTIC FUEL GAS PIPE INSIDE SERVICE RISERS

1.0 INTRODUCTION

- 1.1. The maximum allowable temperatures for plastic piping systems used for fuel gas distribution are defined by Part 192, Transportation of Natural Gas and Other Gas by Pipeline: Minimum Safety Standards, Subchapter I), Pipeline Safety, of Title 49, Transportation, of the U. S. Code of Federal Regulations. By an act of Congress, the U. S. Department of Transportation regulates pipeline safety.
- 1.2. Section 375, *Service Lines: Plastic*, of Part 192 of the U. S. Pipeline Safety Regulations allows the use of properly designed metal-sleeved plastic riser pipe. A point that must be considered in proper design is the temperature that can develop in the above-ground portion of the metal riser and its effect on the strength properties of the plastics gas carrier pipe. Section 121, *Design of Plastic Pipe*, of Part 192 limits the allowable operating temperature of a thermoplastic pipe to the highest value for which the pipes long-term hydrostatic strength has been established, except that it may not exceed 140°F.
- 1.3. There has been some concern that the portion of a plastic riser pipe that is brought up out of the ground inside a protective metal sleeve for connection to a gas meter located outdoors may experience considerably higher temperatures than buried pipe, possibly even above the 140°F limit for some period of time. Since metal-sleeved risers may be exposed to direct sunlight, they could become heated to higher than ambient temperatures. This report presents conclusions from test data gathered in a 2017-2019 study showing the temperatures that may be obtained by thermoplastics pipe installed inside a metal protective sleeve and the conditions under which those temperatures occur. The data from earlier testing in the 1970's has been included in APPENDIX B for historical reference to the maximum temperature study.

2.0 CONCLUSIONS

- 2.1. The results of the study in APPENDIX A, further informs the conclusions from an earlier study in APPENDIX B and points to the following conclusions regarding proper design and installation of thermoplastic pipe gas service risers:

- 2.1.1. The difference in the average temperature of the PE with an annular space between the PE and metal casing of 1/16-inch and 1/6-inch, inclusive of all the sun exposure orientations and structure orientation positions in relation to the annular space, was 1.53°F in Henderson, NV and 1.70°F in Tempe, AZ.
- 2.1.2. The above grade portion of the PE in a riser can be effectively encased in metal tubing if an annular space is maintained even at spacings of 1/16 inches. The spacing between the PE pipe or tubing and metal casing is not required to be uniform.
- 2.1.3. The average annual (2018) temperature of the PE in the above ground portion of the riser (no gas flow) inclusive of all the sun exposure orientations and structure orientation positions in relation to the annular space in Tempe, AZ. is 79.7°F and in Henderson, NV., 74.7°F. This is well below the median annual (2018) temperature of the PE of 91.4°F in Tempe, AZ. and 87.6°F in Henderson, NV.
- 2.1.4. Knowing that PE follows an Arrhenius response to temperature and understanding the concept of Miner's Rule showing the cumulative effect of stress at different conditions for varying durations of time, the application of a HDB at 100°F is conservative for all areas of the U.S. even, the southwestern region where the average annual (2018) temperature of the PE in a riser approaches only 80°F.

APPENDIX A
2017 - 2018 TEST DATA
INVESTIGATION OF TEMPERATURES ATTAINED BY
PLASTIC FUEL GAS PIPE INSIDE SERVICE RISERS

1.0 INTRODUCTION

1.1. This investigation presents test data taken over a period of 18 months through a study by Southwest Gas (SWG), Arizona State University (ASU) and R.W. Lyall at Southwest Gas Emergency Response Centers in Tempe, AZ and Henderson, NV. The data shows the annual average temperatures that may be obtained by thermoplastics pipe installed inside a metal protective sleeve at various air-gap distances between the casing and PE and at various orientations of that air-gap to building structures on the North, East, South and West sides. The report includes:

1.1.1. A description of the test equipment, the test locations, riser test configuration and the results obtained when evaluating for the effects of:

- Air-gap between casing and PE
- Orientation of air-gap to the compass
- Orientation of air-gap to the structure
- Geographical location

1.1.2. An evaluation of the influence of temperature cycling on the hydrostatic strength of polyethylene pipe.

2.0 TEST ASSEMBLIES

2.1. The sixteen (16) assemblies used for this study consisted of 5-foot lengths of 1 CTS polyethylene tubing installed in a 5-foot length of 1-1/2-inch O.D. metal casing made from 0.075-inch wall thickness tubing. The two ends of the metal casing were capped with an access hole in the top cap for the thermal couples to exit the casing assembly. The plastic pipe was secured in the metal pipe by thumbscrews locked in place so the annular space could be maintained at three (3) different air-gaps and the plastic did not touch the metal pipe in four locations evenly spaced around the casing. **Figure A.1** shows a cross section of the metal casing and PE tubing with air-gap spacings of 1/16-inch, 1/10-inch in two places 180° apart, and 1/6-inch. **Figure A.2** shows the test

riser assembly. The riser was buried two (2) feet in the ground up to the first set of thumb screws and the thermocouples were placed about $\frac{1}{2}$ -inch above the second set of thumb screws to ensure accurate spacing at the thermocouple location.

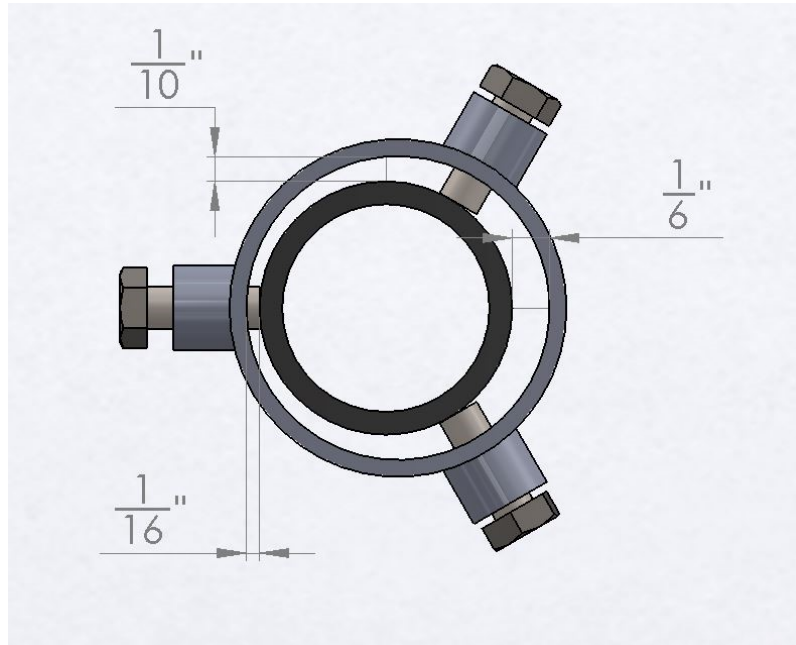

Figure A.1: Cross sectional view of PE tubing in metal casing

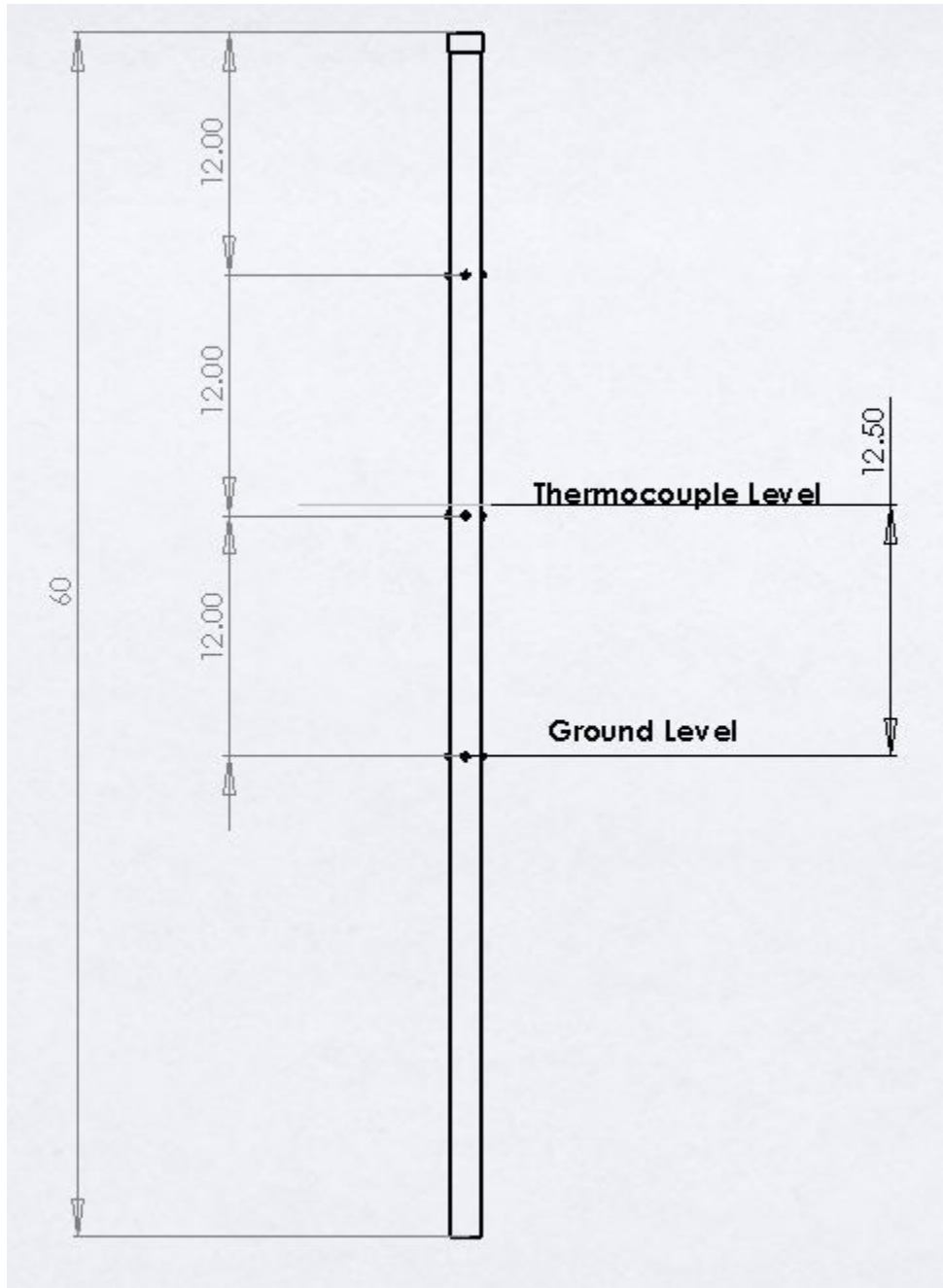

Figure A.2: Test Riser Assembly

- 2.2. Each riser assembly included four (4) thermocouples with the sensing element bored into the mid-wall of the plastic pipe at 12 ½ inches above ground level which is the typical plastic termination point for SWG riser installations. A HOBO UX120 4-Channel Thermocouple Data Loggers was installed at each of the sixteen (16) locations to capture daily temperature data at five-minute increments. Each of the Data Loggers were housed in a protective, weatherproof casing with dimensions of 6.75" x 5" x 2.25" as shown in **Figure A.3**. **Figure A.4** shows an installed data logger with foil wrapped cardboard protective cover to protect against direct sun. Gas service risers installed in a South facing direction at the Henderson, NV test site is shown in **Figure A.5**. A close-up of the West facing riser assembly being installed is shown in **Figure A.6**.



Figure A.3: Data logger housing



Figure A.4: Installed data logger



Figure A.5: Henderson, NV service risers (south facing)



Figure A.6: Henderson, NV riser assembly (west facing)

3.0 FIELD SITE CONFIGURATIONS

3.1. Installation of the test riser assemblies at the SWG Emergency Response Center in Henderson, Nevada was completed on April 20, 2017. **Table A.1** presents the installation details for Risers A through H, while the site layout is illustrated in **Figure A.7**. The first collection of data was performed on June 28, 2017.

Table A.1: Riser Placement and Description for Henderson, NV

Location: Henderson, NV					
Riser	Installation Side of the Building	Air-Spacing of North Side	Air-Spacing of West Side	Air-Spacing of South Side	Air-Spacing of East Side
A	North	1/16"	1/10"	1/6"	1/10"
B	East	1/10"	1/16"	1/10"	1/6"
C	South	1/16"	1/10"	1/6"	1/10"
D	South	1/10"	1/6"	1/10"	1/16"
E	South	1/6"	1/10"	1/16"	1/10"
F	West	1/10"	1/16"	1/10"	1/6"
G	West	1/16"	1/10"	1/6"	1/10"
H	West	1/10"	1/6"	1/10"	1/16"

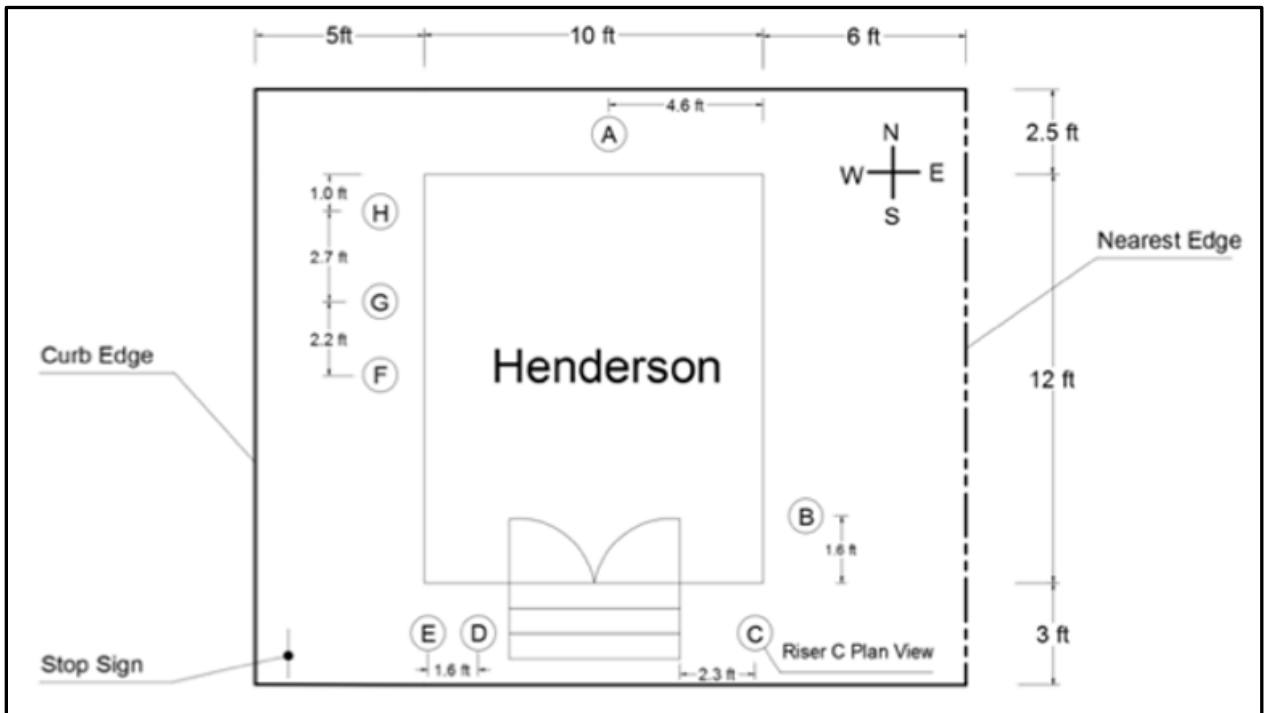

Figure A.7: Henderson, NV site layout

- 3.2. Installation of the test risers at the SWG Emergency Response Center in Tempe, Arizona was done on June 1, 2017. **Table A.2** presents the installation details for Risers I through P, while the site layout is illustrated in **Figure A.8**. The first collection of data was performed on June 27, 2017.

Table A.2: Riser Placement and Description for Tempe, AZ

Location: Tempe, AZ					
Riser	Installation Side of the Building	Air-Spacing of North Side	Air-Spacing of West Side	Air-Spacing of South Side	Air-Spacing of East Side
I	North	1/16"	1/10"	1/6"	1/10"
J	East	1/10"	1/16"	1/10"	1/6"
K	South	1/16"	1/10"	1/6"	1/10"
L	South	1/10"	1/6"	1/10"	1/16"
M	South	1/6"	1/10"	1/16"	1/10"
N	West	1/10"	1/16"	1/10"	1/6"
O	West	1/16"	1/10"	1/6"	1/10"
P	West	1/10"	1/6"	1/10"	1/16"

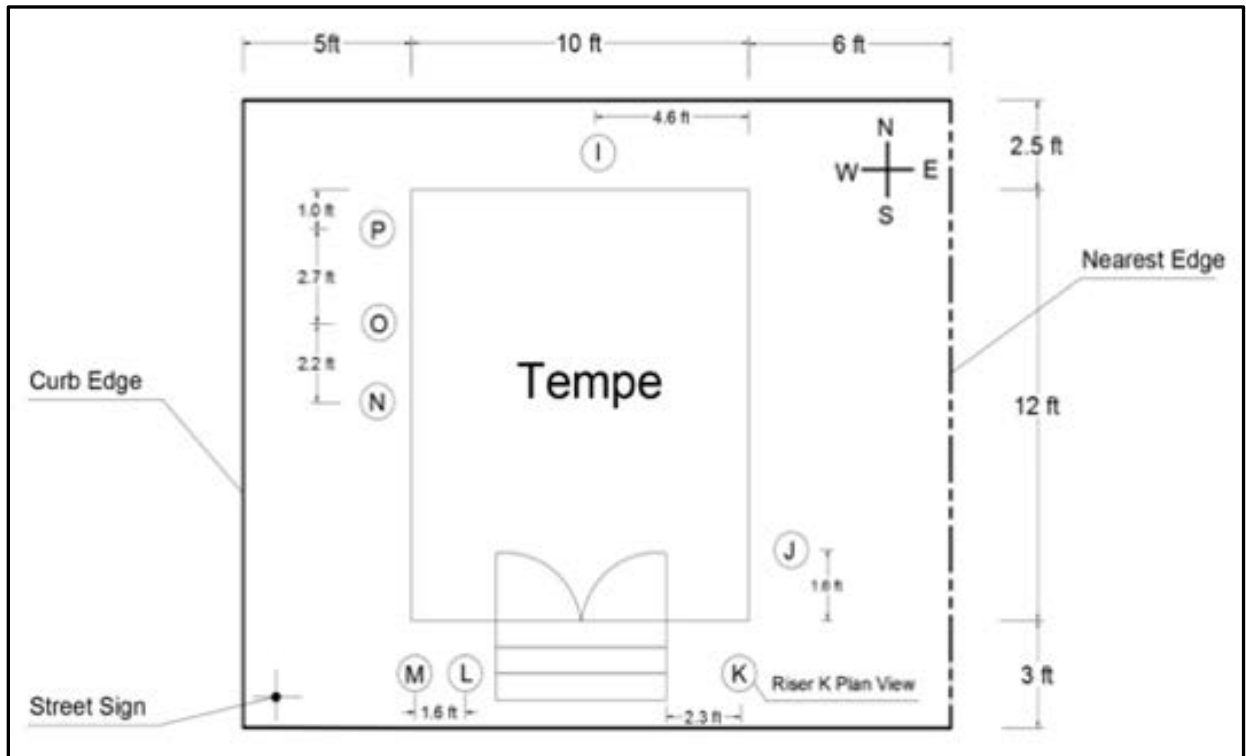

Figure A.8: Tempe, AZ site layout

4.0 FINDINGS AND RESULT

4.1. Henderson, NV: Temperature Variations at Different Riser Spacing

- 4.1.1. **Table A.3** presents temperature variations at different riser spacing. The highest, lowest and average temperature difference between riser spacing 1/6 in. and 1/16 in. were 5.12°F, 0.26°F and 1.53°F, respectively. The highest, lowest and average temperature difference between riser spacing 1/6 in. and 1/10 in. were 4.16°F, 0.39°F and 0.97°F, respectively. The highest, lowest and average temperature difference between spacing 1/16 in. and 1/10 in. were 1.76°F, 0.52°F and 2.17°F.
- 4.1.2. The average monthly riser temperatures at different riser spacing over a 19-month period are illustrated in **Figure A.9**.
- 4.1.3. The maximum, minimum, and average 2018 annual temperatures by month are illustrated in **Figure A.10**.

Table A.3: Temperature Variations Between Different Air-Gap spacings (Henderson, NV)

Henderson, Nevada				
Riser Spacing Option #1	Riser Spacing Option #2	Difference of Highest Riser Temperature (°F)	Difference of Lowest Riser Temperature (°F)	Difference of Average Riser Temperature (°F)
1/16 in.	1/6 in.	5.12	0.26	1.53
1/6 in.	1/10 in.	4.16	0.39	0.97
1/16 in.	1/10 in.	1.76	0.52	2.17

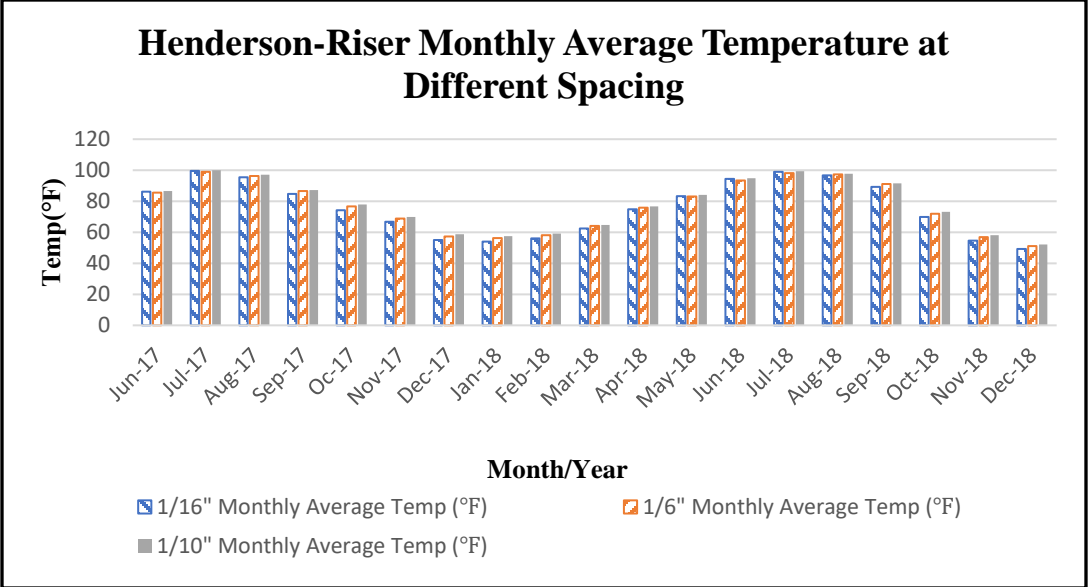

Figure A.9: Henderson average monthly riser temperatures @ different spacing

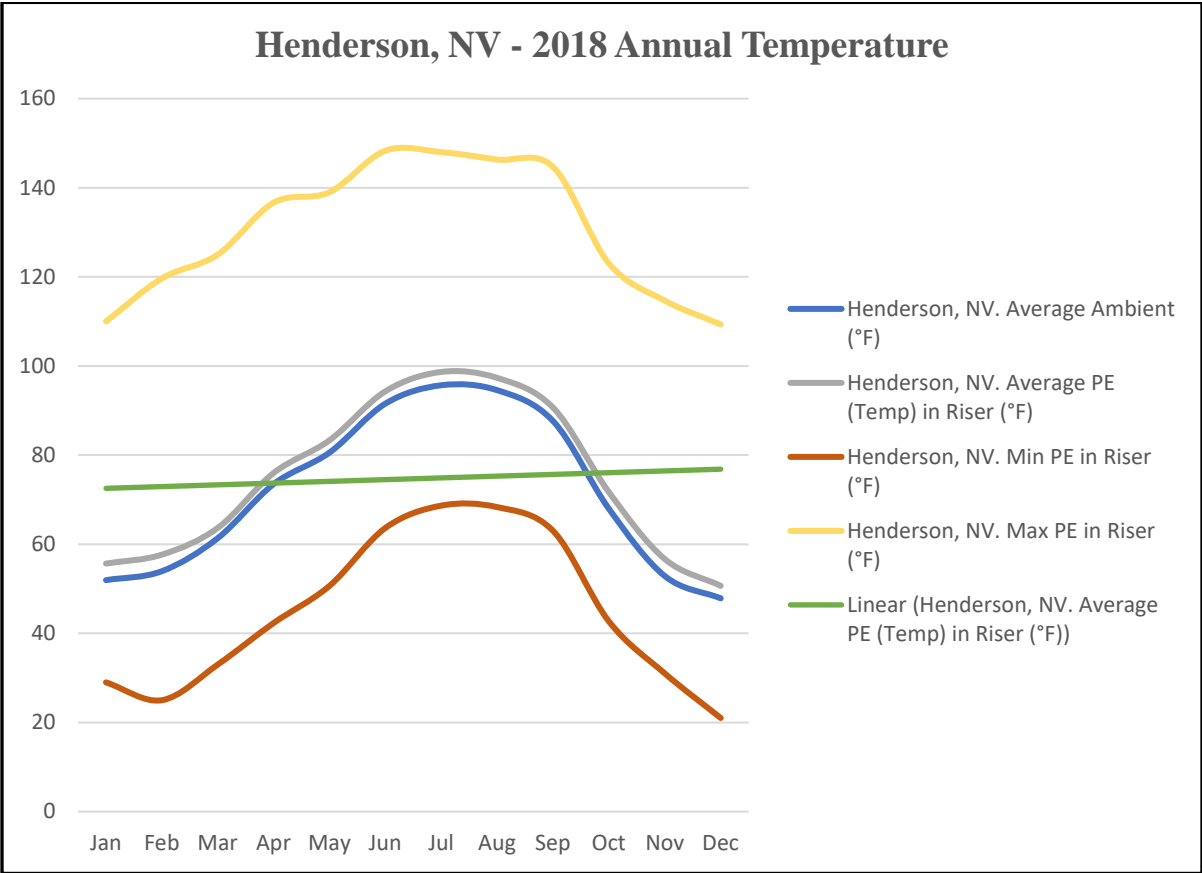

Figure A.10: Henderson annual temperatures by month

4.2. Tempe, AZ: Temperature Variations at Different Riser Spacing

4.2.1. **Table A.4** presents temperature variations between different riser spacing. The highest, lowest and average temperature difference between riser spacing 1/6 in. and 1/16 in. were 2.42°F, 0.49°F and 1.7°F, respectively. The highest, lowest and average temperature difference between riser spacing 1/6 in. and 1/10 in. were 1.91°F, 0.48°F and 0.45°F, respectively. The highest, lowest and average temperature difference between spacing 1/16 in. and 1/10 in. were 1.71°F, 0.72°F and 1.47°F.

4.2.2. The average monthly riser temperatures at different riser spacing over a 19-month period are illustrated in **Figure A.11**.

4.2.3. The maximum, minimum, and average 2018 annual temperatures by month are illustrated in **Figure A.12**.

Table A.4: Temperature Variations Between Different Air-Gap spacings (Tempe, AZ)

Tempe, Arizona				
Riser Spacing Option #1	Riser Spacing Option #2	Difference of Highest Riser Temperature (°F)	Difference of Lowest Riser Temperature (°F)	Difference of Average Riser Temperature (°F)
1/16 in.	1/6 in.	2.42	0.49	1.70
1/6 in.	1/10 in.	1.91	0.48	0.45
1/16 in.	1/10 in.	1.71	0.72	1.47

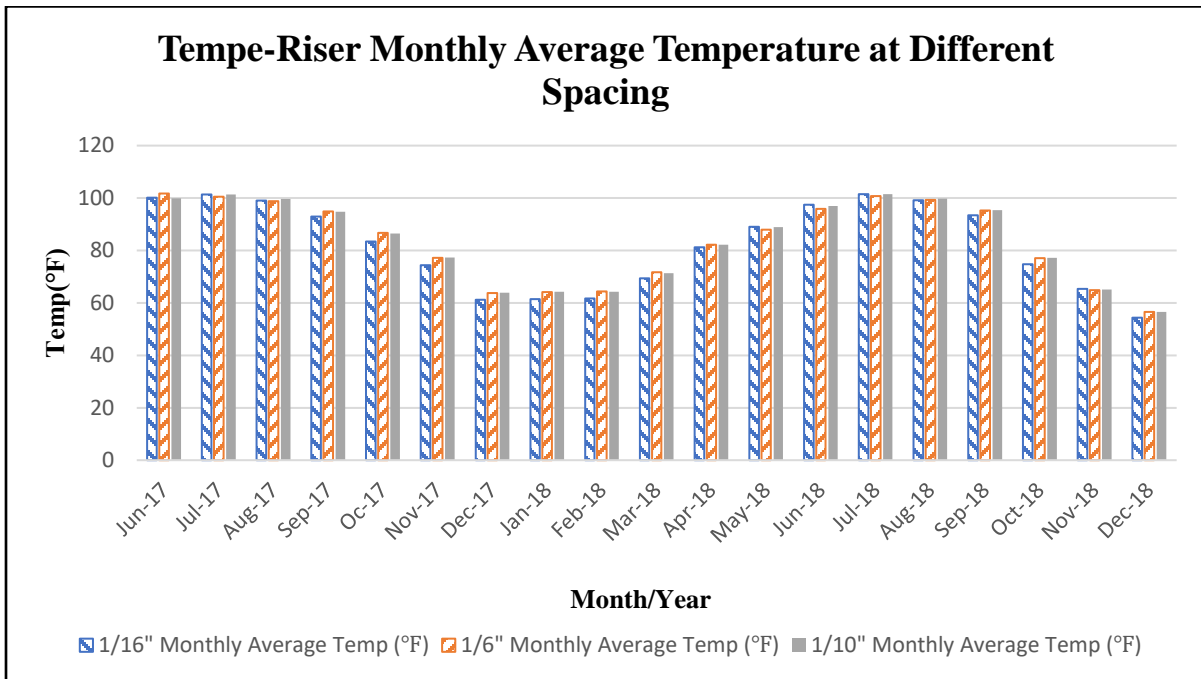

Figure A.11: Tempe average monthly riser temperatures @ different spacing

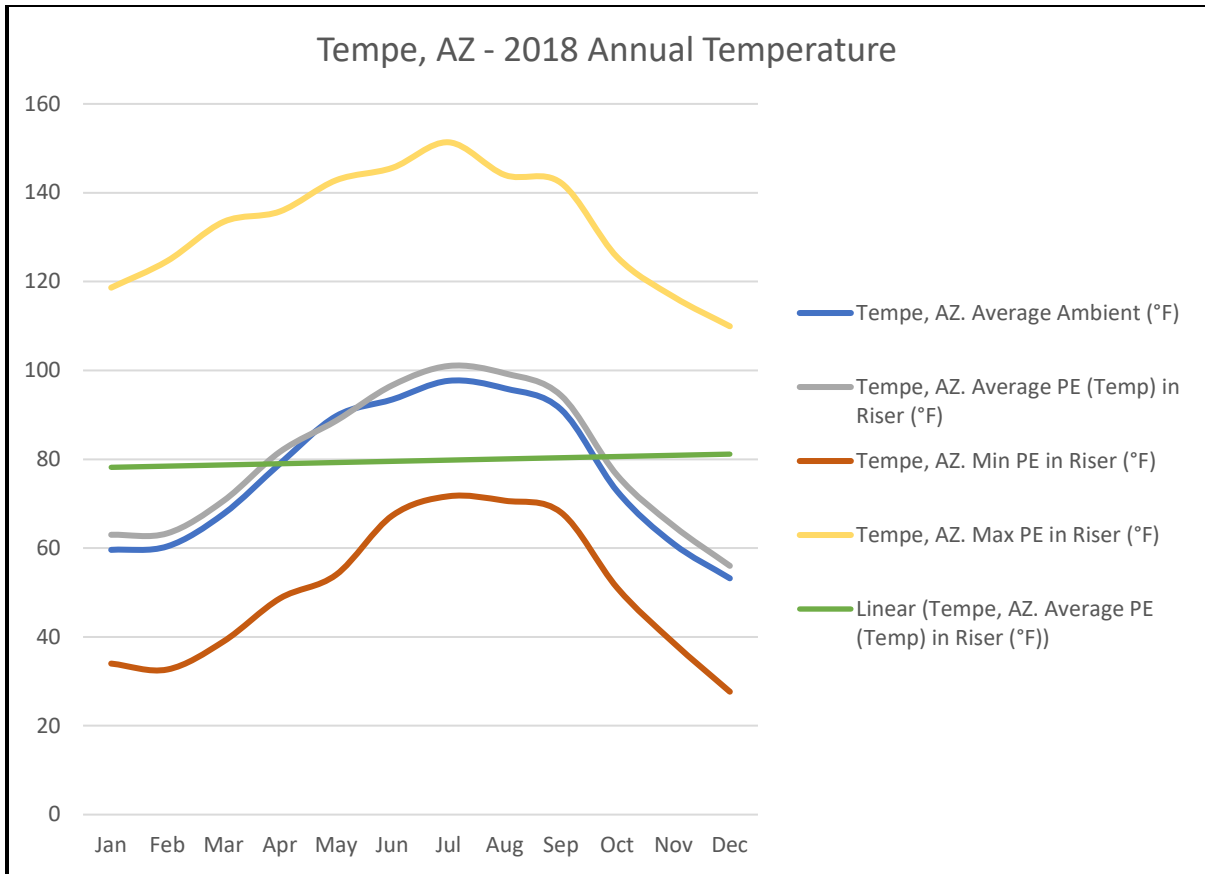

Figure A.12: Tempe annual temperatures by month

5.0 INFLUENCE OF TEMPERATURE CYCLING ON HYDROSTATIC DESIGN PROPERTIES OF POLYETHYLENE PIPE

- 5.1. A committee of the Plastics Pipe Institute regularly compiles and evaluates data obtained from testing thermoplastics pipe. The procedure is defined in ASTM D 2837, "Obtaining Hydrostatic Design Bases for Thermoplastic Pipe Materials". The committee issues a regularly updated report, TR-4, listing materials by their long-term strength categories. Consult the most recent TR-4 report, available from The Plastics Pipe Institute, for current listings.

- 5.2. The maximum, minimum, and average annual, monthly, and daily temperature ranges experienced by the plastic pipe in a metal casing located in high temperature regions of the southwestern U.S. with air-gaps ranging from 1/16 – 1/6 inches have been well established by the series of experiments described in this report. The Plastic Pipe Institute (PPI) Handbook of Polyethylene, 2nd Edition, establishes that the long-term strength properties of PE pipe materials are significantly affected by temperature. The operating temperature above a base temperature results in the decrease in a pipe material long-term HDS and an

operating temperature below the base temperature yields an increase in the pipe material long-term HDS.

- 5.3. The Chairman of the Hydrostatic Stress Board (HSB) has addressed the applicability of the HDB at the average annual temperature with the following comments¹.
 - 5.3.1. “Logic to base the “service temperature” on the average annual temperature was provided previously in which Miner’s Rule was cited. Specifically, the concept in which the effect of different conditions for varying durations is cumulative. In further exploring Miner’s Rule, this “cumulative time” is then compared to a target, i.e. 50 yrs. Designs can be adjusted if the “cumulative time” is less than target. Scenarios such as this could occur when operating at maximum or excursion conditions for some extended duration. In considering the operation of a pipe system, the controls are designed to maintain the target conditions which in turn, shifts the cumulative effect to the norm – minimize the effect of the maximum or excursion conditions.”
 - 5.3.2. “For polyethylene, the material is shown to follow an Arrhenius response, the effect (or “acceleration”) is greater at higher temperatures and less at lower ones. Also, there is discussion included in the PPI PE Handback 2nd ed, Chapter 3 Part A.2 (Temperature Compensating Multipliers) in that, the Hydrostatic Design Stress (HDS) is shown to decrease as expected when operating above the base temperature of 73F but then “yields the opposite effect when operating below the base temperature”. Of course, polyethylene is a semi-crystalline material, therefore continued increases below the base temperature is not limitless.”
 - 5.3.3. “As a measure of safety, a design factor is applied to the HDB where the calculated HDS is subsequently used to determine the pressure rating.”
 - 5.3.4. “In summary of the above, the HDB is applicable at the average annual temperature.”

¹ Letter from Sarah Patterson, PPI Technical Director to Southwest Gas June 6, 2015

APPENDIX B
1970'S TEST DATA
INVESTIGATION OF MAXIMUM TEMPERATURES ATTAINED BY PLASTIC
FUEL GAS PIPE INSIDE SERVICE RISERS

1.0 INTRODUCTION

1.1. This investigation presents test data showing the maximum temperatures that may be obtained by thermoplastics pipe installed inside a metal protective sleeve and the conditions under which the maximum temperatures occur. The report includes:

1.1.1. A description of the test equipment, the environment, and the results obtained when evaluating for the effects of:

- Wall contact
- Venting
- Shading
- Various insulating materials
- Geographical location

1.1.2. A correlation of actual and estimated service riser temperatures across the U.S.A.

1.1.3. An evaluation of the influence of temperature cycling on the hydrostatic strength of polyethylene pipe.

1.1.4. A description of a plastic-pipe/metal-sleeve riser assembly design that minimizes temperatures in the plastic pipe.

1.1.5. A list of plastic pipe materials that can be operated safely at the temperatures encountered in a properly-designed service riser.

2.0 CONCLUSIONS

2.1. The results of the study in APPENDIX B, in which a separation of at least 1/6 inch was maintained between plastic and metal, pointed to the following conclusions regarding proper design and installation of thermoplastic pipe gas service risers:

2.1.1. The plastic pipe must not touch the wall of the metal sleeve. Provisions must be included to assure that an annular space of at least 1/6-inch is maintained.

- 2.1.2. In all areas of the U.S. except the desert southwest, 120°F is an appropriate temperature to use as the hydrostatic design basis for the plastic pipe.
- 2.1.3. In the desert areas of southwestern U.S., 140°F should be used as the appropriate temperature for this purpose.
- 2.1.4. Thermoplastic pipe may be utilized safely and effectively in metal-sleeved risers when the above provisions are observed and when pipe selection and design are based upon appropriately established hydrostatic design ratings and the applicable design factors identified in DOT Document 192.

Note: If an installation has less than the 1/6-inch separation used in this study, check the plastic pipe temperature to insure that it does not exceed either the pipe material limitations or the applicable code requirements.

3.0 TEST ASSEMBLIES

- 3.1. The assemblies used for these tests consisted of 3-foot pipe lengths of 3/4-inch IPS polyethylene pipe installed in a 1-1/4-inch metal pipe. The two ends of the plastic pipe were stopped, and the ends of the metal pipe were capped. The plastic pipe was secured in the metal pipe by thumbscrews, so the annular space could be maintained at about 1/6 inch at all points and the plastic did not touch the metal pipe. By adjusting the thumbscrews, the plastic pipe could be brought into contact with the metal pipe when desired.
- 3.2. The assembly included a thermocouple with the sensing element at the mid-wall of the plastic pipe. A continuous strip-chart recorder measured the temperature. **Figure B.1** (Figure 1 in the image) shows a cross section of the assembly, in which the thumbscrews are identified as spacers. Two of these complete test assemblies were used for tests that were carried out at various locations throughout the United States. **Figure B.1** (Figure 2 in the image) is a photograph of a typical test arrangement, showing both test assemblies and the recorder.

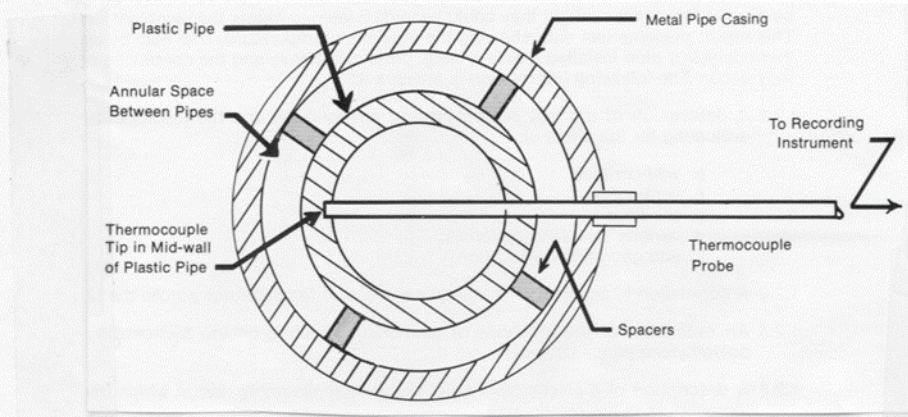

Figure 1. Top Cross-Sectional View of Plastic Pipe in Metal Casing Showing Thermocouple Arrangement

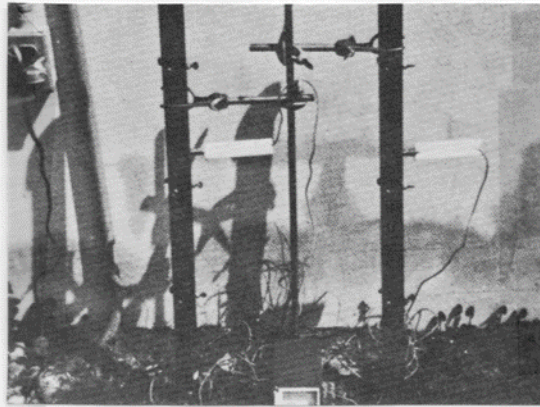

Figure 2. Photograph of Testing Arrangement with Two Test Riser Assemblies and a Temperature Recorder

65

Figure B.1: Assembly Cross-section and Test Arrangement

4.0 SUMMARY OF TEST RESULTS AND OBSERVATIONS

- 4.1. **The effect of wall contact** - In assemblies where the plastic pipe touches the metal pipe, temperatures in excess of 140°F are possible. Examples of several measured temperatures are shown **Table B.1**.

Table B.1: Effect of Wall Contact

Location	Plastic Pipe Touching Metal Wall Temp. °F	Plastic Pipe Controlled (Not Touching) Temp. °F	Ambient Air Temp. °F Unshaded
Wilmington, DE	143	110	94
Orange, TX	149	116	96
Phoenix, AZ	156	122	107
San Francisco, CA	144; 140	-	95

- 4.2. **The effect of shading** - A definite temperature reduction of the plastic pipe was obtained by shading the assembly. With one assembly shaded, its temperature was approximately 10°F lower than that of the unshaded assembly. **Figure B.2** is a photograph showing the arrangement in which one assembly is shaded and the other is exposed to the sun.

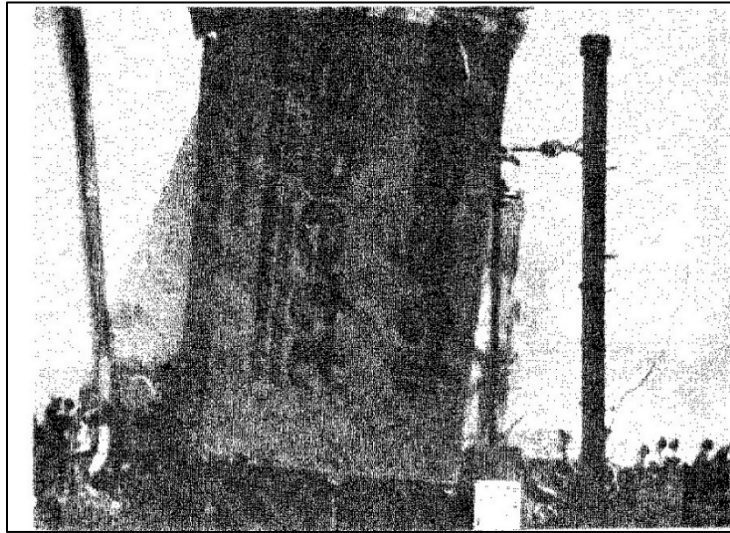

Figure B.2: Arrangement of Test Assemblies and Recorder with One Test Assembly Shaded and One Unshaded

- 4.3. **The effect of venting** - The metal sleeve was vented to determine whether this would have an effect on the temperature of the enclosed plastic pipe. This experiment was carried out because a hypothesis had been advanced that holes in the metal casing would allow air circulation and thus reduce the temperature. To determine the effects of venting, the caps were removed from both ends of one assembly

only and both assemblies were then exposed to exactly the same environment. The plastic pipe temperatures in the vented and unvented assemblies differed by no more than 2°F, so the results indicate that there is no significant advantage to be obtained by venting.

- 4.4. **The effects of insulating materials** - Various types of insulation were placed between the plastic and metal pipes to study their possible effects. The materials evaluated were polystyrene foam, rubber, urethane foam, and asbestos. None of these insulators proved to be any more effective than air in the annular space.
- 4.5. **The effects of geographic location** - A series of tests were performed in several areas of the United States, representing significantly different climatic conditions. The basic test assemblies were used, with stoppered plastic pipes, capped metal casings, and a 1/6-inch insulating air space between the pipe and casing. **Table B.2** lists temperatures recorded at these sites during the summers of 1973 through 1975 and **Table B.3** lists the values obtained during the winter of 1975-76. From these data, it is obvious that the air temperature completely controls the plastic pipe minimum temperature under winter conditions.

Table B.2: Temperatures Attained by Plastic Pipe in Test Assemblies During Summer Seasons

Test Location	Test Dates	Days Operated	Maximum Pipe Temp. (°F)	Total Hours* Pipe Above 100°F	Total Hours* Pipe Above 120°F
Wilmington, DE	July, 1973	10	115	3	0
Tulsa, OK	August, 1973	3	120	4	0
Keene, NH	July, 1973	6	112	2	0
Hialeah, FL	Sept., 1973	9	120	4.5	0
Orange, TX	July, 1974	4	118	5.5	0
Phoenix, AZ	August, 1974	4	124	8	3
San Ramon, CA	July, 1975	3	100	0	0
Pico Rivera, CA	August, 1975	4	112	4.5	0
Borrego Spring, CA	August, 1975	4	125	6.5	2.5

Table B.3: Temperatures Attained by Plastic Pipe in Test Assemblies During Winter Season

Test Locations	Test Dates	Days Operated	Minimum Air Temp. (°F)	Minimum Pipe Temp. (°F)
Wilmington, DE	December, 1975	3	15	15
Fitzwilliam, NH	January, 1976	3	16	16
Soda Springs, ID	February, 1976	7	2	2

5.0 ESTIMATED SERVICE RISER PIPE TEMPERATURES ACROSS THE U.S.

5.1. A correlation has been established between the ambient air temperature and the plastic pipe temperature in the simulated meter riser device, placed in stringent summertime environments. The value of this correlation is that it permits estimation of the number of hours the pipe will be above 120°F or above 100°F from a knowledge of the air temperature vs. time plot. Following are several such relationships:

- When the air temperature is between 100°F and 105° F for 7-1/2hours, the temperature of the plastic pipe will be above 120° F for 2-1/2 hours.
- When the air temperature is between 100°F and 102°F for 3 hours, the temperature of the plastic pipe will be above 120°F for 1 hour.
- If the air temperature is less than 100°F, the plastic pipe temperature will not reach 120°F.
- If the air temperature is below 80°F, the plastic pipe temperature will not reach 100°F.
- Air temperatures between 80°F and 99°F will probably cause the plastic pipe temperature to exceed 100°F. The pipe temperature will likely be above 100°F for about one-third of the daylight hours that the air temperature is between 80°F and 99°F.

5.2. A typical air temperature vs. plastic pipe temperature relationship is shown in **Figure B.3**. A number of such relationships were used to arrive at the observations listed in **5.1** above.

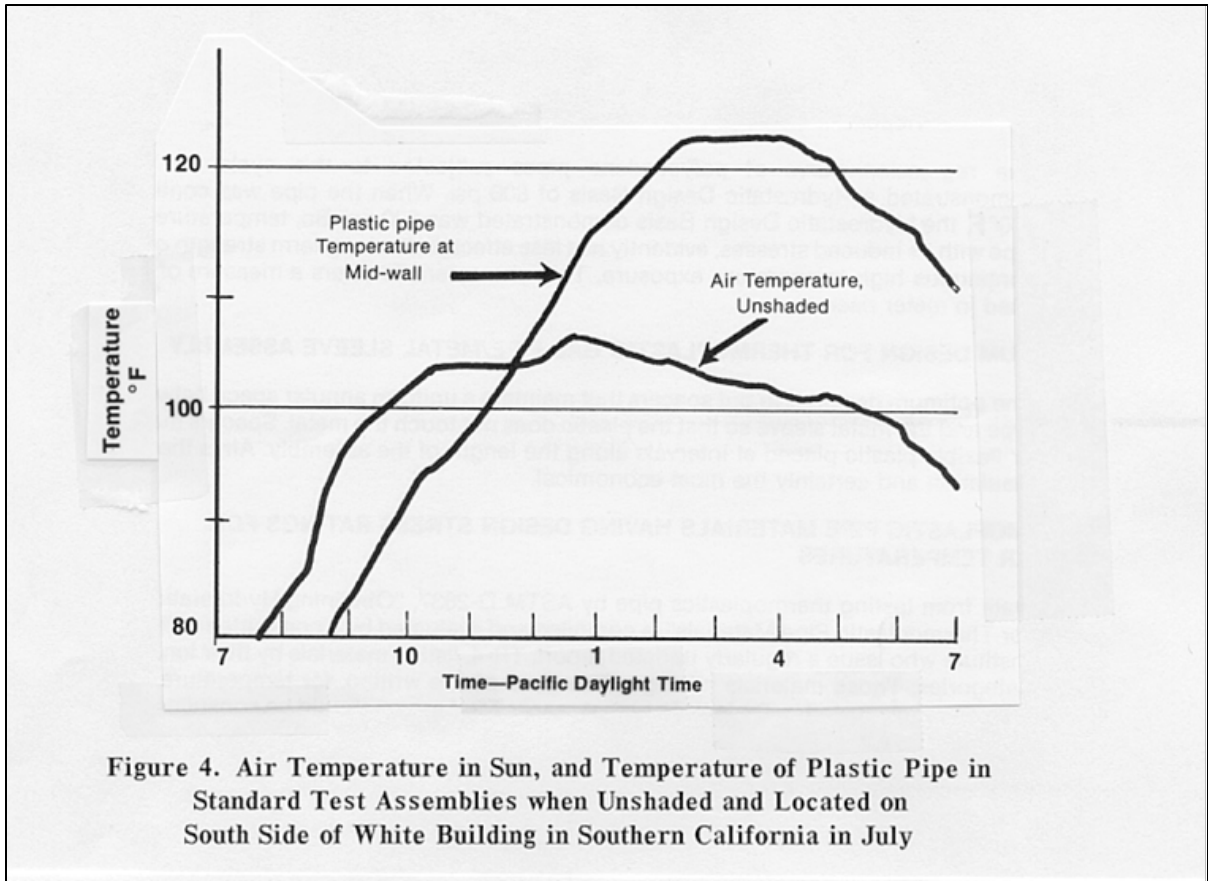

Figure 4. Air Temperature in Sun, and Temperature of Plastic Pipe in Standard Test Assemblies when Unshaded and Located on South Side of White Building in Southern California in July

Figure B.3: Typical air vs. pipe temperatures

5.3. The United States Weather Bureau issues specific climatic data from key U.S. cities on a monthly basis. Such data allowed use of the relationships described in the preceding section of this report to estimate how many hours per year the plastic pipe in the metal casing would exceed 120°F. The appended **Table B.4**, consisting of multiple pages, shows data from the U.S. Summer Weather Record for 21 cities during the period from 1971 to 1974. For each of these cities, listed data include the highest temperature attained during the months of June through September, the highest temperature during the year, and number of days during the year when the temperature exceeded 90°F. The last column lists the estimated percentage of time during the year that the plastic pipe in a metal sleeve would have reached 120°F or higher in an unshaded stringent environment. Note that, in most cases, this column shows 0%. Phoenix is the only notable exception, and here the 120°F temperature is attained less than 2% of the time.

6.0 INFLUENCE OF TEMPERATURE CYCLING ON HYDROSTATIC DESIGN PROPERTIES OF POLYETHYLENE PIPE

- 6.1. In plastic pipe design, the practice is to employ the highest temperature of the application as the basis for selecting the Recommended Hydrostatic Design Stress (RHDS). Such practice ensures a conservative stance to follow when the environment of the application is not fully defined or the influences of variable temperatures on the pipe are not known.
- 6.2. The temperature ranges experienced by the plastic pipe in a metal casing have been well established by the series of experiments described in this report. An evaluation of the effect on polyethylene pipe under temperature cycling conditions has shown that the pressure-bearing capability of the pipe is better when cycled than when held continuously at the highest temperature. In this temperature cycling evaluation, the Hydrostatic Design Basis of the pipe was determined using the method defined in ASTM D-2837, "Obtaining Hydrostatic Design Basis for Thermoplastic Pipe Materials". Water was used as the pressure-imposing fluid and its temperature was subjected to the following program:
 - 6.2.1. Hold at 73°F for three hours.
 - 6.2.2. Raise to 140°F in a one-hour period.
 - 6.2.3. Hold at 140°F for three hours.
 - 6.2.4. Reduce to 73°F in one hour.
 - 6.2.5. Repeat.

The regression curve of polyethylene pipes subjected to this cycle for 10,000 hours demonstrated a Hydrostatic Design Basis of 800 psi. When the pipe was held continuously at 140°F, the Hydrostatic Design Basis was 630 psi. So, evidently, temperature cycling of PE pipe with its induced stresses has less effect on the long-term strength of the pipe than continuous high temperature exposure. This characteristic offers a measure of safety to pipe used in a meter riser.

7.0 OPTIMUM DESIGN FOR THERMOPLASTIC GAS PIPE WITH METAL SLEEVE ASSEMBLY

- 7.1. For an optimum design, use spacers that maintain a uniform annular space between the plastic pipe and the metal sleeve so that the plastic does not touch the metal. Spacers may be rubber or flexible plastic, placed at intervals along the length of the assembly. Air is the most effective insulation and certainly the most economical. Products incorporating these design features are available commercially.

8.0 THERMOPLASTIC PIPE MATERIALS HAVING DESIGN STRESS RATINGS FOR HIGHER TEMPERATURES

8.1. A committee of the Plastics Pipe Institute regularly compiles and evaluates data obtained from testing thermoplastics pipe. The procedure is defined in ASTM D 2837, "Obtaining Hydrostatic Design Bases for Thermoplastic Pipe Materials". The committee issues a regularly updated report, TR-4, listing materials by their long-term strength categories. Consult the most recent TR-4 report, available from The Plastics Pipe Institute, for current listings.

Table B.4: Highest Temperature Data from Weather Stations Around the U.S.

Source: U.S. Weather Bureau Publications

Note: The last column in this table is an estimate of the percent of hours per year when a plastic pipe encased in a metal pipe, with an annular air space of 1/6 inch, would have a temperature above 120°F.

Location and Year	Highest Temperature, °F				Year High, °F	No. Days over 90°F	% hours over 120°F
	June	July	Aug.	Sept.			
Birmingham, AL							
1971	98	97	92	92	98	31	0
1972	92	94	97	94	97	45	0
1973	89	94	91	95	95	30	0
1974	93	95	91	90	95	34	0
Total, 4 years						140	0
Phoenix, AZ							
1971	111	114	106	110	114	154	1
1972	112	115	116	105	116	160	1.1
1973	115	115	111	115	108	172	1.1
1974	116	113	110	110	116	180	1.1
Total, 4 years						666	1.1
Los Angeles, CA							
1971	77	82	90	91	101	9	0
1972	77	87	90	89	90	2	0
1973	90	92	85	98	98	6	0
1974	80	84	78	86	100	4	0
Total, 4 years						21	0
San Diego, CA							
1971	79	83	88	94	101	7	0
1972	77	92	90	85	92	4	0
1973	90	80	83	93	93	5	0
1974	82	86	77	84	94	2	0
Total, 4 years						18	0

Location and Year	Highest Temperature, °F				Year High, °F	No. Days over 90°F	% hours over 120°F
	June	July	Aug.	Sept.			
San Francisco, CA							
1971	83	79	87	103	103	5	0
1972	89	98	91	90	98	3	0
1973	98	79	83	85	98	6	0
1974	103	83	92	89	103	1	0
Total, 4 years						15	0
Denver, CO							
1971	98	101	94	94	101	38	0
1972	89	100	98	85	100	75	0
1973	95	103	94	87	103	33	0.022
1974	96	95	94	93	96	46	0
Total, 4 years						192	0.005
Wilmington, DE							
1971	92	95	90	88	95	14	0
1972	90	95	94	91	95	10	0
1973	95	94	100	95	100	24	0
1974	92	95	90	88	95	17	0
Total, 4 years						65	0
Jacksonville, FL							
1971	98	96	94	92	98	71	0
1972	95	97	96	96	97	76	0
1973	95	96	95	94	96	81	0
1974	93	93	93	92	93	53	0
Total, 4 years						281	0
Miami, FL							
1971	91	91	90	87	96	28	0
1972	91	89	89	89	91	20	0
1973	90	90	90	90	91	13	0
1974	92	93	92	92	93	51	0
Total, 4 years						112	0
Atlanta, GA							
1971	93	91	89	87	93	11	0
1972	90	94	92	92	94	18	0
1973	89	94	91	94	94	16	0
1974	91	92	91	88	92	14	0
Total, 4 years						59	0

Location and Year	Highest Temperature, °F				Year High, °F	No. Days over 90°F	% hours over 120°F
	June	July	Aug.	Sept.			
Chicago, IL							
1971	97	90	94	94	94	35	0
1972	94	93	93	87	93	12	0
1973	91	95	95	94	95	29	0
1974	90	97	89	88	97	9	0
Total, 4 years						85	0
Boston, MA							
1971	94	94	93	92	94	15	0
1972	86	94	88	88	94	9	0
1973	97	96	99	95	99	19	0
1974	93	95	91	87	95	7	0
Total, 4 years						50	0
Minneapolis, MN							
1971	96	90	97	94	97	10	0
1972	92	91	97	83	97	9	0
1973	98	95	93	85	98	13	0
1974	88	101	90	85	101	15	0
Total, 4 years						47	0
Concord, NH							
1971	95	92	85	88	95	5	0
1972	87	92	88	85	92	3	0
1973	96	95	95	93	96	16	0
1974	92	93	92	88	93	11	0
Total, 4 years						35	0
New York, NY							
1971	93	96	92	91	96	18	0
1972	86	95	95	92	95	14	0
1973	95	94	98	96	98	18	0
1974	95	95	92	88	95	17	0
Total, 4 years						67	0
Charlotte, NC							
1971	94	91	90	89	94	12	0
1972	90	94	92	93	94	28	0
1973	90	97	94	93	97	25	0
1974	93	91	92	89	93	14	0
Total, 4 years						79	0

Location and Year	Highest Temperature, °F				Year High, °F	No. Days over 90°F	% hours over 120°F
	June	July	Aug.	Sept.			
Bismarck, ND							
1971	84	93	102	100	102	18	0
1972	90	95	100	94	100	19	0
1973	92	108	107	84	108	23	0
1974	96	100	94	91	100	26	0
Total, 4 years						86	0
Columbus, OH							
1971	94	89	88	87	94	7	0
1972	86	92	91	86	92	3	0
1973	91	91	94	93	94	17	0
1974	88	93	91	85	93	11	0
Total, 4 years						38	0
Philadelphia, PA							
1971	92	96	89	92	96	20	0
1972	86	95	96	90	96	18	0
1973	93	93	99	97	99	28	0
1974	95	95	93	90	95	22	0
Total, 4 years						88	0
Spokane, WA							
1971	90	99	101	86	101	31	0
1972	90	96	103	88	103	17	0
1973	100	95	95	93	100	29	0
1974	94	97	94	84	97	18	0
Total, 4 years						95	0
Cheyenne, WY							
1971	92	95	91	86	95	9	0
1972	82	93	91	81	93	3	0
1973	91	98	89	79	98	9	0
1974	89	89	87	86	89	0	0
Total, 4 years						21	0